

hiRUN

STOP
RESET

POWERFUL OPERATION & COMPACT SIZE

SINGLE PHASE VECTOR INVERTER

hiRUN
N 50

HYUNDAI INVERTER



HYUNDAI INVERTER *h*RUN N50

HYUNDAI *h*RUN N50 Inverter is,

More economical for single phasing input.

Adaptable, as it is possible to select various operation methods.

Optimal not only at high speeds but also low speeds in its driving characteristics.

Convenient for users through development of various optional products.



*h*RUN N50 Model Number Information

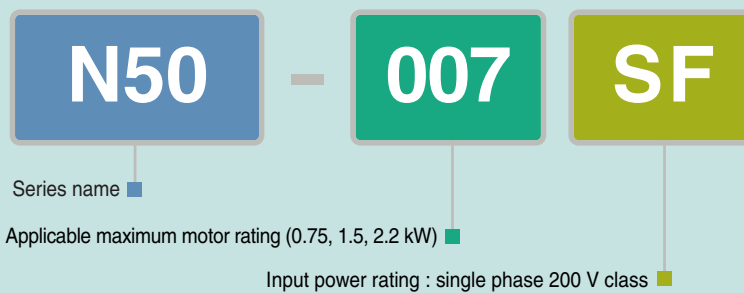

*h*RUN N50 Series Type

Motor(kW)	0.75	1.5	2.2
Single phase, 200 V class	●	●	●

POWERFUL OPERATION & COMPACT SIZE

HYUNDAI INVERTER



HYUNDAI Inverter N50
Single Phase Vector Inverter

C O N T E N T S

Feature	04	Protective Function	14
External Dimension Diagram	05	Terminal Function	15
Operation	06	Application Wiring Apparatus & Option	16
General Specification	07	Option	17
Function List	09	Proper Operation	18

Feature

Vector inverter for single phasing input only

–High torque of 200% or greater at speeds as low as 1 Hz during starting and operation.

Realize triples driving by adding current suppression

- Stable operation even under the instantaneous impact load and overload is realized through the addition of over-current level adjusting function.
- Maintain constant speed even at the time of sudden load change by rapid speed restoration characteristics.
- Applicable to the transfer machine, treadmill, industrial washing machine due to its function of momentary current suppression.

Possible to select various operation method

–It is possible to select the operation method of either RS485 communication driving or analog signal driving for the user's convenience.

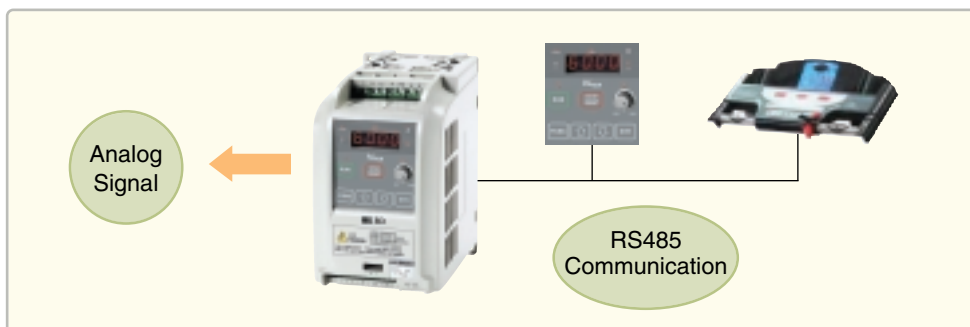

Compact size for easy to install

–Reduction in cubic volume, 52% compare to the N100 series.

Develop optional product for user convenience

–DOP05 : Economical remote operator
Operation & display function



External Dimension Diagram

The N50 series inverter can be easily operated with the standard digital operator panel on the main unit. For remote operation, remote operator(DOP05) is available as an option product.

External Dimension

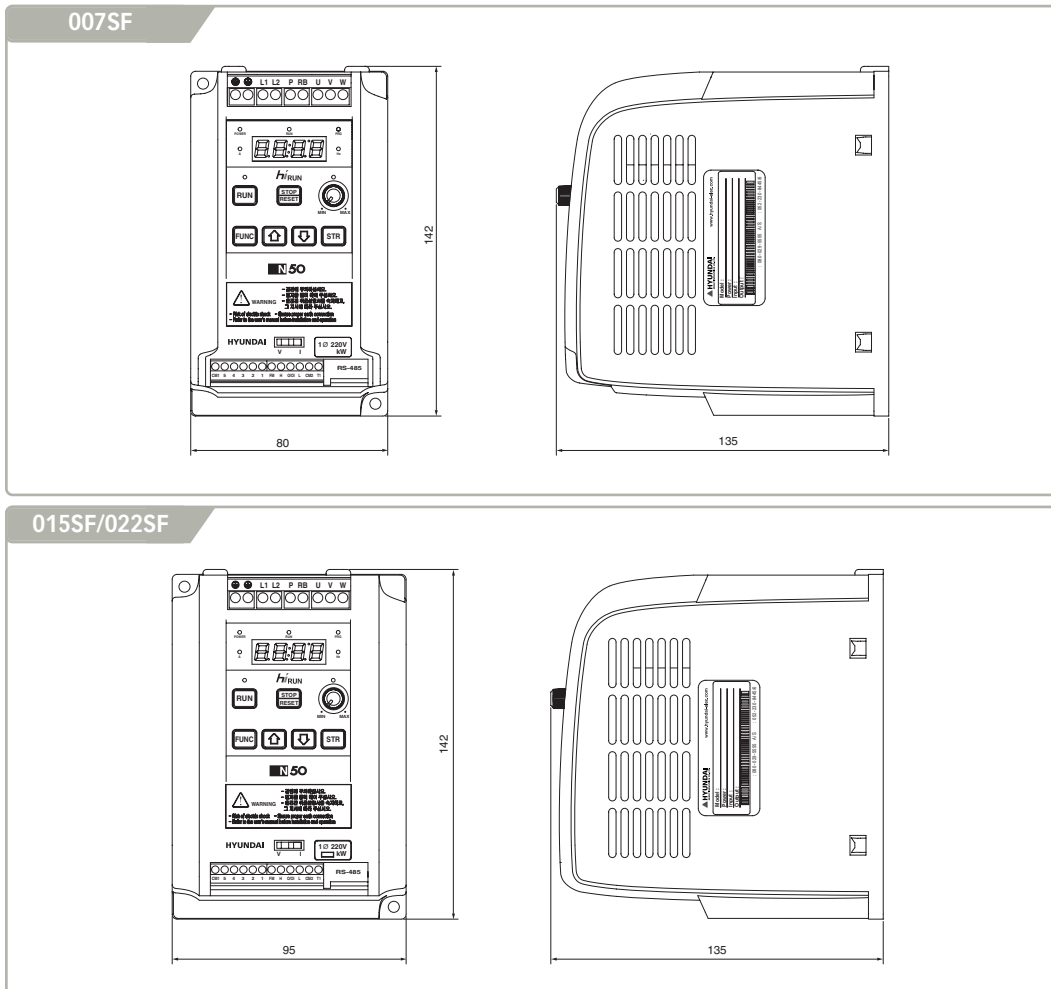

Dimension Table

Type	External Dimension(mm) (W x H x D)	Installation Dimension(mm) (W x H, Ø)	Weight (kg)
007SF	80 x 142 x 135	70 x 130, M4	1.0
015SF	95 x 142 x 135	85 x 130, M4	1.3
022SF			

Operation

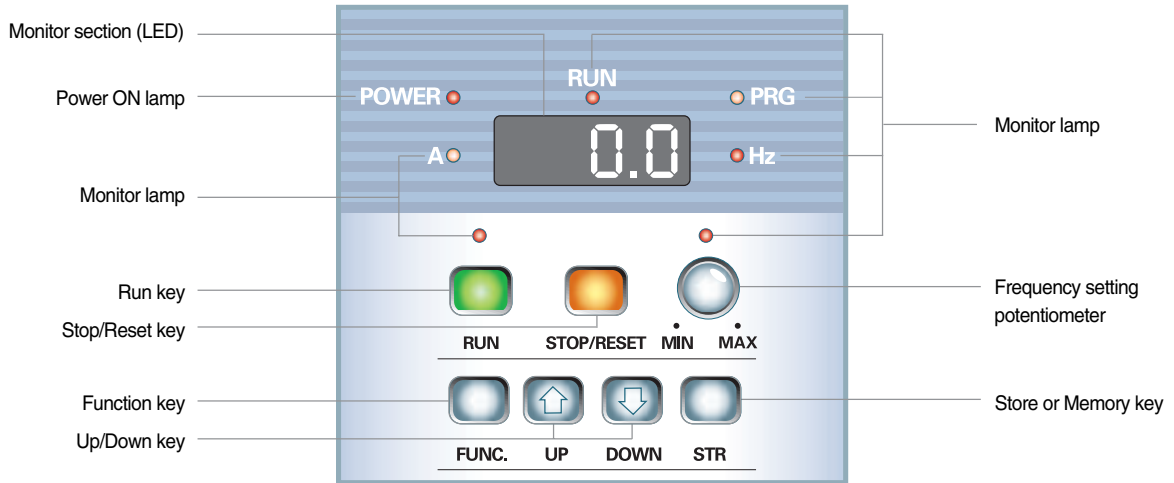

Setting the maximum frequency

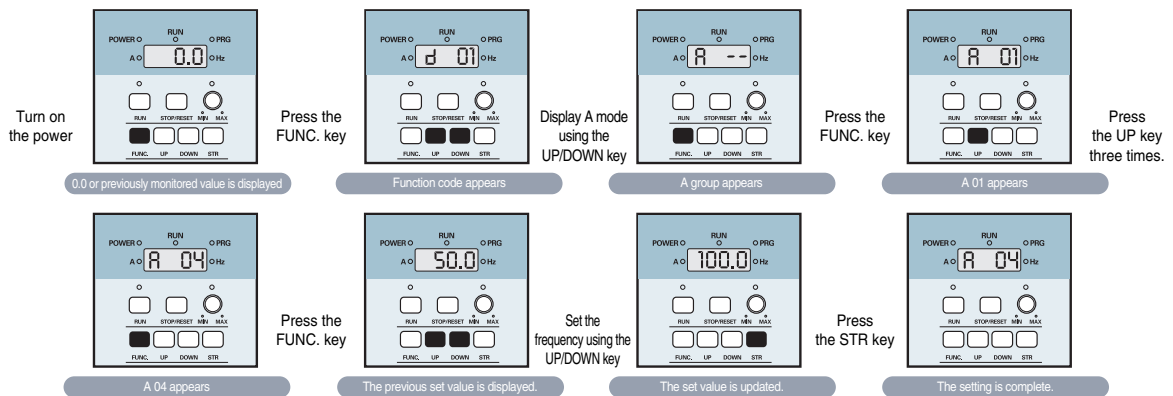

Running the motor (using the speed POT)

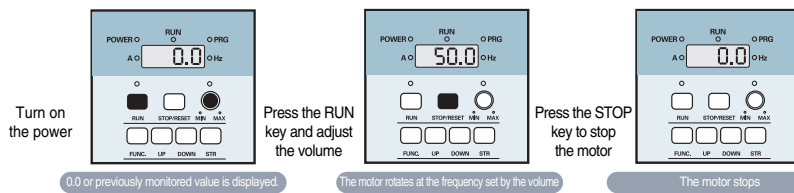

Monitoring the output current

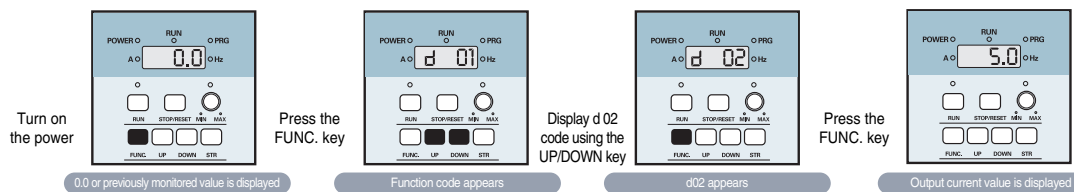

General Specification

Item		Type		
		007SF	015SF	022SF
Model name		N50-007SF	N50-015SF	N50-022SF
Output	Applicable motor capacity (kW)	0.75	1.5	2.2
	Rated output capacity (kVA)	1.9	3.0	4.2
	Rated output current (A)	5.0	7.0	10.0
	Rated output voltage (V)	3-phase, 200~230 V		
	Maximum output frequency (Hz)	400 Hz		
Input	Voltage / frequency	Single phase, 200~230Vac, 50/60 Hz		
	Power conditions	Voltage: $\pm 10\%$ / frequency: $\pm 5\%$		
Control characteristic	PWM method	Space vector PWM		
	Control method	V/F control, sensorless vector control		
	Output frequency range	0.5 ~ 400 Hz		
	Frequency setting resolution	Analog	Max. setting frequency \div 1000 (DC10 V, 4~20 mA)	
		Digital	0.01 Hz (100 Hz and less), 0.1 Hz (100 Hz or more)	
	Frequency precision	Analog	Within 0.1% of maximum output frequency	
		Digital	Within 0.01% of maximum output frequency	
	Overload rating	150% of rated current for 1 minute		
	Starting torque	More than 200% (at 1 Hz)		
	Torque boost	Manual torque boost can be set between 0~50%		
	Acceleration/deceleration time setting	0.1~3000 sec		
	Acceleration/deceleration pattern	Linear, S-curve, U-curve		
	Current stall prevention operation level	Operating current level setting possible(20~200%), enable/disable selection		
	Voltage stall prevention operation level	Operating current level constant, enable/disable selection		
Analog frequency setting	DC 0~5 V or DC 0~10 V / 4~20 mA			
Environment	Ambient temperature	-10~40 (no freezing)		
	Ambient humidity	90% RH or less(non-condensing)		
	Storage temperature	-20~60 (short-term temperature during transport)		
	Installation area	Indoors without corrosive gases, flammable gases, oil mist or dust		
	Altitude and vibration	Maximum 1000m or less above sea level, 5.9 m/s ² or less		
Cooling method		Forced cooling		
Environment protection		IP20		

General Specification

Item			Type		
			007SF	015SF	022SF
Model name			N50-007SF	N50-015SF	N50-022SF
Control characteristic	Input signal	Frequency setting	Analog digital 0 to 5VDC, 0 to 10VDC, 4 to 20 mA, External variable resistor (1 k ~2 k ,1 W), main unit volume resistor Input from control panel		
		Starting signal	Individual selection of forward or reverse run		
		Abnormality reset	Used to reset fault output provided when protective function is activated		
		Multispeed selection	Maximum 16 speeds (each speed can be set between 0 and 400 Hz), speed can be changed during operation		
		2nd function selection	Acceleration/deceleration time, base frequency, maximum frequency, multistage frequency, torque boost, electronic thermal, control method, motor parameter		
		Output stop	Instant shut-off of inverter output (frequency/voltage)		
		Current input selection	Input selection of frequency setting current signal		
		Self-protection function at starting	Self-protection selection of start signal		
		External TRIP contact input	Contact input for when stopping the inverter with external terminal		
		External thermal input	Thermal contact input for when stopping inverter with externally mounted thermal relay		
		Operation mode selection	Control panel or external operation transition selection programmable.		
		Voltage/frequency characteristic	V/f control or sensorless vector control method selection programmable.		
	Operation functions		Multispeed operation, operation mode selection, DC braking, upper/lower frequency setting, frequency jump operation, PID control, AVR, 2-stage accel./decel., instantaneous power failure restart operation, electronic thermal, software lock, carrier frequency adjustment, auto tuning function, RS485 link operation, starting frequency adjustment, jogging operation, retry function, automatic torque boost function, usp function.		
Output signals	Operation status	Inverter running, frequency reached, frequency detection, overload warning fault			
	For meter	Output frequency, output current, output voltage			
Display function	Displayed on control panel	Error details	Fault list, fault history		
	LED Display	Power on (POWER), operational state (RUN), PRG, frequency (Hz), output current (A), RUN terminal, MIN/MAX volume terminal			
Protective and warning functions			Overcurrent shut-off, regenerative overvoltage shut-off, undervoltage, output short circuit, temperature abnormality, overload shut-off (electronic thermal), ground fault protection, external trip, communication error, USP error, EEPROM error		
International direction			CE		

Function List

Monitor Mode / Basic Setting Mode

Function code	Name	Initial value	Minimum value	Maximum value	Unit	Code description	
Monitor	d01	Output frequency monitor	-	0.00	400.0	Hz	0.00~99.99,100.0~400.0 Hz, "Hz" LED on
	d02	Output current monitor	-	0.0	99.9	A	0.0~99.9 A display, "A" LED on
	d03	Output voltage monitor	-	0	-	V	Output voltage display (V)
	d04	Rotation direction monitor	-	-	-	-	"F": forward run, "r": reverse run, " ": stop
	d05	PID feedback monitor	-	0	100	%	0~100% display, effective at PID function selection
	d06	Input terminal status monitor	-	-	-	-	Intelligent input terminal 1~5
	d07	Output terminal status monitor	-	-	-	-	Intelligent output terminal, alarm terminal
	d08	Scaled output frequency monitor	-	0.00	-	-	Scale factor (b14) × frequency data
	d09	Power consumption monitor	-	0	-	W	Displays power consumption at inverter start (W)
	d10	Operating time accumulation monitor	-	0	9999	Hr	Inverter operating accumulation time
	d11	Real operating time monitor	-	0	59	min	Inverter real operating time
	d12	DC link voltage	-	0	-	V	Display the inverter DC link voltage (V)
	d13	Trip event monitor	-	-	-	-	Present trip event
	d14	Trip history 1 monitor	-	-	-	-	Previous 1 trip event
	d15	Trip history 2 monitor	-	-	-	-	Previous 2 trip events
	d16	Trip history 3 monitor	-	-	-	-	Previous 3 trip events
	d17	Trip count	-	0	9999	-	Trip accumulation count
Setting	F01	Output frequency setting	60.00	0.00	400.0	Hz	0.00~99.99 Hz (by 0.01 Hz) 100.0~400.0 Hz (by 0.1 Hz)
	F02	Acceleration time 1 setting	10.0	0.1	3000	sec	0.1~999.9 sec (by 0.1 sec) 1000~3000 sec (by 1 sec)
	F03	Deceleration time 1 setting	10.0	0.1	3000	sec	0.1~999.9 sec (by 0.1 sec) 1000~3000 sec (by 1 sec)
	F04	Rotation direction setting	0	0	1	-	0: forward , 1: reverse
Expanded function	A--	Basic setting functions	-	-	-	-	Setting range: A01~A65
	b--	Fine tuning functions	-	-	-	-	Setting range: b01~b17
	C--	Terminal setting functions	-	-	-	-	Setting range: C01~C23
	H--	Sensorless vector setting functions	-	-	-	-	Setting range: H01~H15

Function List

Expanded Function A Mode

Function code	Name	Initial value	Minimum value	Maximum value	Unit	Code description	
Basic setting	A01	Frequency commanding	0	0	3	-	0: main unit volume, 1: control terminal, 2: standard operator, 3: remote operator (communication)
	A02	RUN commanding	0	0	2	-	0: standard operator, 1: control terminal, 2: remote operator (communication)
	A03	Base frequency setting	60.00	0.00	A04	Hz	0~maximum frequency (A04)
	A04	Maximum frequency setting	60.00	A03	400.0	Hz	A03~400 Hz
External frequency setting	A05	External frequency setting start	0.00	0.00	A04	Hz	0.0~400 Hz (by 0.01 Hz), start frequency at 0 V, 4 mA input
	A06	External frequency setting end	0.00	0.00	A04	Hz	0.0~400 Hz (by 0.01 Hz) end frequency at 10 V, 20 mA input
	A07	External frequency start rate setting	0.0	0.0	100.0	%	Start rate for the analog input
	A08	External frequency end rate setting	100.0	0.0	100.0	%	End rate for the analog input
	A09	External frequency start pattern setting	0	0	1	-	0: start at start frequency 1: start at 0 Hz
A10	External frequency sampling setting	4	1	8	-	1~8 times, analog input filter sampling count	
Multi - stage speed frequency setting	A11	Multispeed frequency 1 setting (1st, 2nd motor)	5.00	0.00	A04	Hz	0.00~400.0 Hz (by 0.01 Hz)
	A12	Multispeed frequency 2 setting (1st, 2nd motor)	10.00	0.00	A04	Hz	0.00~400.0 Hz (by 0.01 Hz)
	A13	Multispeed frequency 3 setting (1st, 2nd motor)	15.00	0.00	A04	Hz	0.00~400.0 Hz (by 0.01 Hz)
	A14	Multispeed frequency 4 setting (1st, 2nd motor)	20.00	0.00	A04	Hz	0.00~400.0 Hz (by 0.01 Hz)
	A15	Multispeed frequency 5 setting (1st, 2nd motor)	30.00	0.00	A04	Hz	0.00~400.0 Hz (by 0.01 Hz)
	A16	Multispeed frequency 6 setting (1st, 2nd motor)	40.00	0.00	A04	Hz	0.00~400.0 Hz (by 0.01 Hz)
	A17	Multispeed frequency 7 setting (1st, 2nd motor)	50.00	0.00	A04	Hz	0.00~400.0 Hz (by 0.01 Hz)
	A18	Multispeed frequency 8 setting (1st, 2nd motor)	60.00	0.00	A04	Hz	0.00~400.0 Hz (by 0.01 Hz)
	A19	Multispeed frequency 9 setting (1st, 2nd motor)	0.00	0.00	A04	Hz	0.00~400.0 Hz (by 0.01 Hz)
	A20	Multispeed frequency 10 setting (1st, 2nd motor)	0.00	0.00	A04	Hz	0.00~400.0 Hz (by 0.01 Hz)
	A21	Multispeed frequency 11 setting (1st, 2nd motor)	0.00	0.00	A04	Hz	0.00~400.0 Hz (by 0.01 Hz)
	A22	Multispeed frequency 12 setting (1st, 2nd motor)	0.00	0.00	A04	Hz	0.00~400.0 Hz (by 0.01 Hz)
	A23	Multispeed frequency 13 setting (1st, 2nd motor)	0.00	0.00	A04	Hz	0.00~400.0 Hz (by 0.01 Hz)
	A24	Multispeed frequency 14 setting (1st, 2nd motor)	0.00	0.00	A04	Hz	0.00~400.0 Hz (by 0.01 Hz)
A25	Multispeed frequency 15 setting (1st, 2nd motor)	0.00	0.00	A04	Hz	0.00~400.0 Hz (by 0.01 Hz)	
A26	Jog frequency setting	0.50	0.50	10.00	Hz	0.5~10.00 Hz (by 0.01 Hz)	
A27	Jog stop operation selection	0	0	2	-	0: free-run, 1: deceleration stop, 2: DC braking	

Function code	Name	Initial value	Minimum value	Maximum value	Unit	Code description	
V/f characteristic	A28	Torque boost mode selection	0	0	1	-	0: manual torque boost, 1: automatic torque boost
	A29	Manual torque boost voltage setting	5.0	0.0	50.0	%	Manual torque boost voltage setting
	A30	Manual torque boost frequency setting	10.0	0.0	100.0	%	Manual torque boost frequency setting
	A31	V/F characteristic curve selection	0	0	2	-	0: constant torque, 1: reduced torque (1.7), 2: sensorless vector control
	A32	Output voltage gain setting	100.0	20.0	100.0	%	20~100%
DC braking	A33	DC braking function selection	0	0	1	-	0: disable, 1: enable
	A34	DC braking frequency setting	0.50	0.00	10.00	Hz	0.50~10.00 Hz (by 0.01 Hz)
	A35	DC braking output delay time setting	0.0	0.0	5.0	sec	0.0~5.0 sec (by 0.1 sec), free run time
	A36	DC braking force setting	10.0	0.0	50.0	%	0~50%, by 1%
	A37	DC braking time setting	0.0	0.0	10.0	sec	0.0~10.0 sec (by 0.1 sec)
Upper/lower limit jump frequency	A38	Frequency upper limit setting	0.00	0.00	400.0	Hz	A39~A04 (by 0.01 Hz)
	A39	Frequency lower limit setting	0.00	0.00	400.0	Hz	0.00~A38 (by 0.01 Hz)
	A40	Jump frequency setting 1	0.00	0.00	400.0	Hz	0.00~400.0 Hz (by 0.01 Hz)
	A41	Jump frequency band-width setting 1	0.00	0.00	10.00	Hz	0.00~10.00 Hz (by 0.01 Hz)
	A42	Jump frequency setting 2	0.00	0.00	400.0	Hz	0.00~400.0 Hz (by 0.01 Hz)
	A43	Jump frequency band-width setting 2	0.00	0.00	10.00	Hz	0.00~10.00 Hz (by 0.01 Hz)
	A44	Jump frequency setting 3	0.00	0.00	400.0	Hz	0.00~400.0 Hz (by 0.01 Hz)
PID control	A45	Jump frequency band-width setting 3	0.00	0.00	10.00	Hz	0.00~10.00 Hz (by 0.01 Hz)
	A46	PID function selection	0	0	1	-	0: PID control off, 1: PID control on
	A47	PID P gain setting	10.0	0.1	100.0	%	0.1~100.0% (by 0.1 sec)
	A48	PID I gain setting	10.0	0.0	100.0	sec	0.0~100 sec (by 0.1 sec)
	A49	PID D gain setting	0.0	0.0	100.0	sec	0.0~100 sec (by 0.1 sec)
	A50	PID scale rate setting	100.0	0.1	1000	-	0.1~1000.0 (by 0.1 sec)
Automatic Voltage Regulation (AVR)	A51	PID feedback input method setting	0	0	1	-	0: current input, 1: voltage input
	A52	AVR function selection	0	0	2	-	0: constant on, 1: constant off, 2: off during deceleration
Acceleration/deceleration setting	A53	Motor input voltage setting	220	200	240	V	200/220/230/240
	A54	2-stage acceleration time setting	10.0	0.1	3000	sec	0.1~999.9 sec (by 0.1 sec)
	A55	2-stage deceleration time setting	10.0	0.1	3000	sec	1000~3000 sec (by 1 sec)
	A56	2-stage accel./decel. switching method setting	0	0	1	-	0: terminal (2CH), 1: transition frequency (A57, A58)
	A57	Acceleration transition frequency setting	0.00	0.00	400.0	Hz	0.00~400.0 Hz (by 0.01 Hz)
	A58	Deceleration transition frequency setting	0.00	0.00	400.0	Hz	0.00~400.0 Hz (by 0.01 Hz)
	A59	Acceleration pattern setting	0	0	2	-	0: linear, 1: S-curve, 2: U-curve
Input signal adjustment	A60	Deceleration pattern setting	0	0	2	-	0: linear, 1: S-curve, 2: U-curve
	A61	Voltage signal offset setting	0.0	-10.0	10.0	-	Voltage offset
	A62	Voltage signal gain setting	100.0	0.0	200.0	-	Voltage gain
	A63	Current signal offset setting	0.0	-10.0	10.0	-	Current offset
	A64	Current signal gain setting	100.0	0.0	200.0	-	Current gain
	A65	External voltage input selection	0	0	1	-	0: 5 V input, 1: 10 V input

Function List

Expanded Function b Mode

Function code	Name	Initial value	Minimum value	Maximum value	Unit	Code description	
Instantaneous power failure restart	b01	Selection of restart mode after instantaneous failure	0	0	3	-	0: alarm output after trip 1: restart at 0 Hz 2: resume operation after frequency matching 3: resume previous frequency after frequency matching then decelerate to stop, trip after stop overcurrent trip, restart up to 3 times, overvoltage trip, restart up to 3 times, undervoltage trip, restart up to 10 times
	b02	Allowable instantaneous power failure time setting	1.0	0.3	1.0	sec	0.3~1.0 sec (by 0.1 sec)
	b03	Reclosing stand by after instantaneous power failure recovered	1.0	0.3	3.0	sec	0.3~3.0 sec (by 0.1 sec)
Electronic thermal	b04	Electronic thermal level setting	100.0	20.0	120.0	%	0.2X (inverter rated current)~1.2X (inverter rated current)
	b05	Electronic thermal characteristic selection	1	0	1	-	0: SUB (reduced torque characteristic) 1: CRT (constant torque characteristic)
Overload restriction	b06	Overload restriction mode selection	1	0	3	-	0: overload, overvoltage restriction mode OFF 1: overload restriction mode ON 2: overvoltage restriction mode ON 3: overload, overvoltage restriction mode ON
	b07	Overload restriction level setting	125.0	20.0	200.0	%	0.2X (inverter rated current)~2.0X (inverter rated current)
	b08	Overload restriction constant setting	1.0	0.1	10.0	sec	Deceleration rate when inverter restricts overload 0.1~10.0 sec (by 0.1 sec)
Software lock (LOCK)	b09	Software lock selection	0	0	3	-	0: All parameters are locked when SFT from terminal is on. 1: All parameters except frequency setting are locked when SFT from terminal is on. 2: All parameters are locked 3: All parameters except frequency setting are locked.
Others	b10	Start frequency adjustment	0.50	0.50	10.00	Hz	0.50~10.00 Hz (by 0.01 Hz)
	b11	Carrier frequency adjustment	5.0	0.5	160	kHz	0.5~16 kHz (by 0.1 kHz)
	b12	Initialization mode selection	0	0	1	-	0: Trip history initialization 1: Data initialization
	b13	Initial value selection (country code)	0	0	2	-	0: Korea version 1: Europe version 2: US version
	b14	Frequency conversion value setting	1.00	0.01	99.99	-	0.01~99.99 (by 0.01)
	b15	Stop key validity selection during terminal operation	0	0	1	-	0: stop enabled 1: stop disabled
	b16	Restarting after free-run stop signal selection	0	0	2	-	Operation setting when the free-run stop is cancelled 0: 0 Hz restart 1: frequency matching restart 2: free run stop
	b17	Communication number	1	1	32	-	Communication number setting is 1 to 32

Expanded Function C Mode

Function code	Name	Initial value	Minimum value	Maximum value	Unit	Code description	
Intelligent input terminal setting	C01	Intelligent input terminal 1 setting	0	0	14	-	0: forward run command (FW) 1: reverse run command (RV) 2: 1st multispeed command (CF1) 3: 2nd multispeed command (CF2) 4: 3rd multispeed command (CF3) 5: 4th multispeed command (CF4) 6: jog operation command (JG) 7: 2-stage acceleration/deceleration command (2CH) 8: free-run stop command (FRS) 9: external trip (EXT) 10: unattended start protection (USP) 11: software lock function (SFT) 12: analog input current selection signal (AT) 13: reset (RS)
	C02	Intelligent input terminal 2 setting	1	0	14	-	
	C03	Intelligent input terminal 3 setting	2	0	14	-	
	C04	Intelligent input terminal 4 setting	3	0	14	-	
	C05	Intelligent input terminal 5 setting	8	0	14	-	
Intelligent input terminal contact	C07	Intelligent input terminal 1 contact	0	0	1	-	0: NO, 1: NC
	C08	Intelligent input terminal 2 contact	0	0	1	-	0: NO, 1: NC
	C09	Intelligent input terminal 3 contact	0	0	1	-	0: NO, 1: NC
	C10	Intelligent input terminal 4 contact	0	0	1	-	0: NO, 1: NC
	C11	Intelligent input terminal 5 contact	0	0	1	-	0: NO, 1: NC
Intelligent output terminal setting	C13	Intelligent output terminal 11 setting	1	0	5	-	0: running signal (RUN) 1: frequency arrival signal (FA1) 2: set frequency arrival signal (FA2) 3: overload advance notice signal (OL) 4: PID control error deviation signal (OD) 5: fault alarm signal (AL)
Intelligent output terminal contact	C15	Output terminal 11 a/b contact setting	0	0	1	-	0: NO, 1: NC
Others	C17	Monitor signal (FM) selection	0	0	2	-	0: output frequency, 1: output current, 2: output voltage
	C18	Analog meter gain adjustment	100.0	0.0	250.0	%	0 (45%)~250 (220%) (by 1)
	C19	Analog meter offset adjustment	0.0	-3.0	10.0	%	-3.0~10.0% (by 0.1)
	C20	Overload advance notice signal level setting	100.0	50.0	200.0	%	0.5 x inverter rated current~2.0
	C21	Acceleration arrival signal frequency setting	0.00	0.00	400.0	Hz	0.0~400 Hz (by 0.01 Hz)
	C22	Deceleration arrival signal frequency setting	0.00	0.00	400.0	Hz	0.0~400 Hz (by 0.01 Hz) x inverter rated current
	C23	PID deviation level setting	10.0	0.0	100.0	%	0~100% (by 0.01)

Function List

Expanded Function H Mode

Function code	Name	Initial value	Minimum value	Maximum value	Unit	Code description	
Sensorless vector control	H01	Auto-tuning setting	0	0	1	-	0: auto-tuning OFF, 1: auto-tuning ON
	H02	Motor data setting (standard/auto-tuning)	0	0	1	-	0: standard motor constant, 1: auto-tuning data
	H03	Motor capacity	1	1	3	-	1: 0.75 kW 2: 1.5 kW 3: 2.2 kW
	H04	Motor poles	4	2	8	-	2/4/6/8
	H05	Motor rated current	-	0.1	100.0	A	Motor rated current
Motor constant	H06	Primary resistance R ₁	-	0.001	30.00		setting range: 0.001~30.00
	H07	Secondary resistance R ₂	-	0.001	20.00		setting range: 0.001~20.00
	H08	Primary inductance L _s	-	0.1	2000.0	mH	setting range: 0.1~2000.0 mH
	H09	Transient inductance L _{sig}	-	0.01	100.0	mH	setting range: 0.01~100.0 mH
	H10	No-load current I _o	-	0.1	100.0	A	setting range: 0.1~100.0 A
Auto-tuning motor constant	H11	Primary resistance R ₁	-	0.001	30.00		setting range: 0.001~30.00
	H12	Secondary resistance R ₂	-	0.001	20.00		setting range: 0.001~20.00
	H13	Primary inductance L _s	-	0.1	2000.0	mH	setting range: 0.1~2000.0 mH
	H14	Transient inductance L _{sig}	-	0.01	100.0	mH	setting range: 0.01~100.0 mH
	H15	No-load current I _o	-	0.1	100.0	A	setting range: 0.1~100.0 A

Protective Function

Various functions are provided for the protection of the inverter and motor, they also perform the protection function when the inverter breaks down.

Function	Description	Display	
		Standard operator	Remote operator
Overcurrent protection	When the inverter output current exceeds the rated current by more than approximately 200% while the motor is locked or reduced in speed, the protection circuit activates, halting inverter output.	E04	Over.C
Overload protection (electronic thermal) regenerative	When the inverter output current causes the motor to overload, the electronic thermal trip in the inverter cuts off the inverter output.	E05	Over.L
Overvoltage protection	If regenerative energy from the motor or the main power supply voltage is high, the protective circuit activates to cut off the inverter output when the voltage of DC link exceeds the specification.	E07	Over.V
Communication error	The inverter output is cut off when communication to the inverter has an error due to external noise, excessive temperature rise, or other factors.	E60	Com.ERR
Undervoltage protection	When the input voltage to the inverter decreases, the control circuit does not function normally. When the input voltage is below the specification, the inverter output is cut off.	E09	Under.V
Output short-circuit	The inverter output was short-circuited. This condition causes excessive current for the inverter, so the inverter output is turned off.	E34	PM.ERR
USP error	The USP error is indicated when the power is turned on with the inverter in RUN state. (Enabled when the USP function is selected.)	E13	USP
EEPROM error	The inverter output is cut off when the EEPROM in the inverter has an error due to external noise, excessive temperature rise, or other factors.	E08	EEPROM
External trip	When the external equipment or unit has an error, the inverter receives the corresponding signal and cuts off the output.	E12	EXTERNAL
Temperature trip	When the temperature in the main circuit increases due to cooling fan failure, the inverter output is cut off (only for the model with a cooling fan).	E21	OH.FIN

Terminal Function

Main Circuit Terminal

Terminal symbol	Terminal name	Function
L1, L2	Main power supply input terminal	Single phase 200V class
U, V, W	Inverter output terminal	Connects to the motor
P, RB	External resistor connection terminal	Connects the braking resistor (option)
	Ground connection terminal	Ground connection (to prevent electric shock and reduce noise)

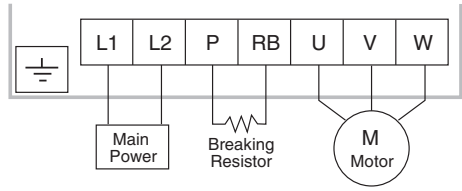

Control Circuit Terminal

Signal	Terminal symbol	Terminal name	Terminal function
Input signal	5	Forward run command (FW), reverse run command (RV), Multi-speed commands 1~4 (CF1~4), 2-stage accel./decel. command (2CH), Reset (RS), free run stop (FRS), external trip (EXT), Second control function setting (SET), terminal software lock (SFT), Unattended start protection (USP), Current input selection (AT), jog operation (JG)	Contact input: Closed: on (operating) Open: off (stop)
	4		
	3		
	2		
	1		
	CM1		
Monitor signal	FM	Output frequency meter, output current meter, output voltage meter	Analog frequency meter
Frequency command signal	H	Power supply for frequency setting	10 VDC
	O/OI	Voltage frequency command signal	0~5 VDC, input impedance 10 k
		Current frequency command signal	4~20 mA, input impedance 250
	L	Common terminal for frequency command	
Output signal	11	Intelligent output terminal; Run status signal (RUN), frequency arrival signal (FA1), Set frequency arrival signal (FA2), overload advance notice signal (OL), PID error deviation signal (OD), and alarm signal (AL)	Maximum 27 VDC, 50 mA
	CM2	Common terminal for output signals	

Application Wiring Apparatus & Option

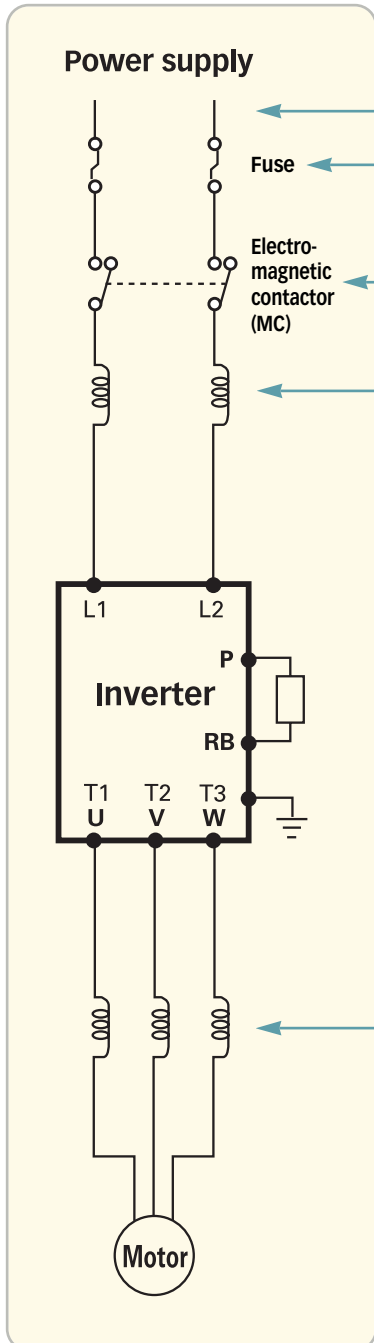

Standard Apparatus (3-Phase input reference)

Motor output (kW)	Inverter model (N50 Series)	Wiring		Applicable equipment
		Power lines	Signal lines	Fuse (class H)
0.75	N50-007SF	1.25 mm ²	0.14 mm ²	10 A
1.5	N50-015SF	2.0 mm ²	~	15 A
2.2	N50-022SF		shielded cable	20 A

- Field wiring connection must be made in accordance with a UL-listed and CSA-certified closed-loop terminal connector sized for the wire gauge required. Connector must be fixed using the crimping tool specified by the connector manufacturer.
- Properly select the capacity of the circuit breaker to be used.
- Check power wire size if cable length exceeds 20 m.
- Use 0.75 mm² wire for the alarm signal wire.

Standard Apparatus

Name	Function
Input-side AC reactor for harmonic suppression/ power coordination/ power improvement	This is useful when harmonic suppression measures must be taken, when the main power voltage unbalance rate exceeds 3% and the main power capacity exceeds 500 kVA, or when a sudden power voltage variation occurs. It also helps to improve the power factor.
AC reactor for vibration reduction/thermal relay malfunction prevention	Vibration may increase when driving a general-purpose motor with an inverter as compared with commercial power operation. Connecting this reactor between the inverter and the motor allows reduction of motor pulsation. When the cable between the inverter and the motor is 10 m or more, inserting the reactor prevents thermal relay malfunction caused by harmonics resulting from inverter switching. A current sensor can be used instead of the thermal relay.

Option

Digital Operator

- Digital operator is economical remote operator.
- Digital operator can control inverter parameter and operating commands.

Specification

Item	Description	
Model name	DOP05	
External dimension	67.5 mm(H) × 64.9 mm(W) × 35.1 mm(D)	
Display	7-segment LED	4-digit 7-segment LED
	Monitor lamp	7 (POWER/RUN/PRG/Hz/A/ RUN key/Volume LED)
Keypad	7 (RUN/STOP(RESET)/FUNC/ UP/DOWN/STR/Volume)	
Communication method	RS485(Modular connection)	
Function	Inverter operation & monitoring	
Connection cable length	1.5 m, 3 m	



Digital Operator (DOP05)

Key configuration

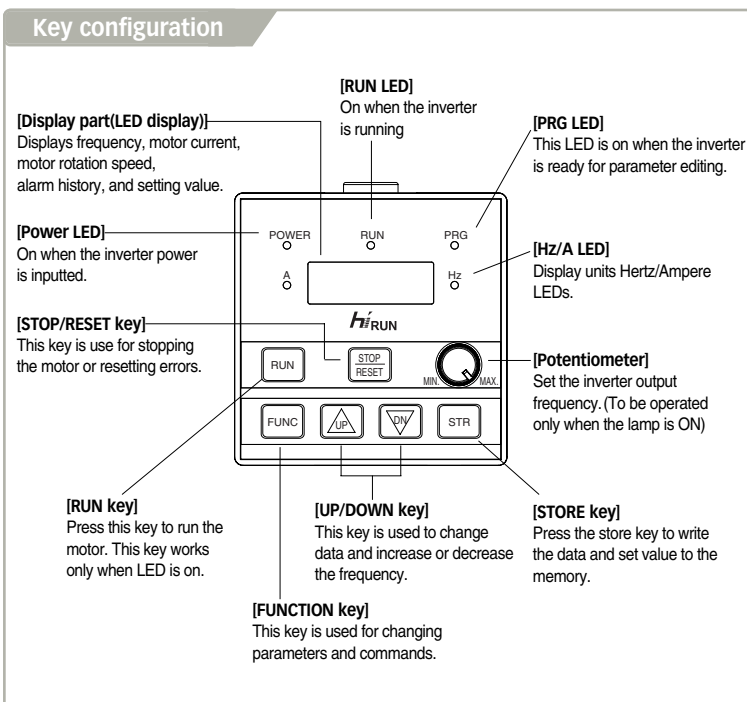

Connection diagram



Proper Operation

- Before use, be sure to read through the Instruction Manual to insure proper operation.
- Note that the inverter requires proper electrical wiring; a specialist should carry out the wiring.
- The inverter in this catalog is designed for general industrial applications. For special applications in fields such as aircraft, outer space, nuclear power, electrical power, transport vehicles, clinics, and submarine relay equipment, please consult us in advance.
- For application in a facility where human safety is at stake or serious losses may occur, be sure to program all safety devices to avoid serious accidents.
- The inverter is used for three-phase AC motor.

Application to General-Purpose Motors

Operating frequency	The overspeed endurance of a general-purpose motor is 120% of the rated speed for 2 minutes (JIS C4004). For operation higher than 60 Hz, it is required to examine the allowable torque of the motor, useful-life of bearings, noise, vibration, etc. In this case, be sure to consult the motor manufacturer as the maximum allowable rpm differs depending on the motor capacity, etc.
Torque characteristics	The torque characteristics of driving a general-purpose motor with an inverter differ from those of driving it with commercial power (starting torque decreases in particular). Carefully check the load torque characteristic of a connected machine and the driving torque characteristic of the motor.
Motor loss & temperature increase	An inverter-driven general-purpose motor heats up swiftly at lower speeds. Consequently, the torque level permitting continuous use decreases with lower motor speeds. Carefully check the torque characteristics.
Noise	When run by an inverter, a general-purpose motor generates noise slightly greater than with commercial power.
Vibration	When run by an inverter at variable speeds, the motor may regenerate vibration, especially because of (a) unbalanced rotor including a connected machine, or (b) resonance caused by the natural vibration frequency of a mechanical system. Particularly, be careful of (b) when operating a machine previously fitted with a constant speed motor at variable speed. Vibration can be minimized by (1) avoiding resonance points using the frequency jump function of the inverter, (2) using a flexible coupling, or (3) placing a rubber shock absorber beneath the motor base.
Power transmission mechanism	Under continuous, low-speed operation, oil lubrication can deteriorate in a power transmission mechanism with an oil-type gear box (gear motor) or reducer. Consult the motor manufacturer for the permissible range of continuous speed. To operate at more than 60 Hz, confirm the machine's ability to withstand the centrifugal force generated.

Application to Special Motors

Gear motor	The allowable rotation range of continuous drive varies depending on the lubrication method or motor manufacturer. (Particularly where oil lubrication is concerned, pay attention to the low frequency range). The Hitachi GA/GX/CX gear motors are of a grease lubrication type. Their grease lubrication capability remains unchanged even if the motor rotating speed decreases.
Brake motor	When using a brake motor, be sure to connect the braking power supply on the primary side of the inverter.
Explosion-proof motor	Inverter drive is not suitable for a safety-enhanced explosion-proof type of motor. The inverter should be used in combination with a pressure-proof and explosion-proof type of motor. Explosion-proof verification is not available for N100 Series. For explosion-proof operation, use an other series of motors.
Synchronous (MS) motor High-speed (HFM) motor	In most cases, the synchronous (MS) motor and the high-speed (HFM) motor are designed and manufactured to meet the specifications suitable for a connected machine. Consult us to select an inverter.
Single-phase motor	A single-phase motor is not suitable for variable-speed operation by inverter drive. Therefore, use a three-phase motor.

Notes on Use: Drive

Run/Stop	Run or stop of the inverter must be done with the keys on the operator panel or through a control circuit terminal. Do not operate by installing an electromagnetic contactor (M) in the main circuit.
Emergency motor stop	When the protective function is operating or the power supply stops, the motor enters the free run stop state. When an emergency stop is required or when the motor should be kept stopped, use the mechanical brake.
High-frequency run	A max. of 360 Hz can be selected on the N50 Series. However, a two-pole motor can attain up to approx. 21,600 rpm, which is extremely dangerous. Therefore, carefully make selection and settings by checking the mechanical strength of the motor and connected machines. Consult the motor manufacturer when it is necessary to drive a standard (general-purpose) motor at over 60 Hz. A full line of high-speed motors is available from manufacturer.

Notes on Use: Installation Location and Operating Environment

- Avoid installation in areas of high temperature, excessive humidity, or where moisture can easily condense, as well as areas that are dusty, subject to corrosive gasses, mist from liquid used for grinding, or salt. Install the inverter in a well-ventilated and vibration-free room avoiding direct sunlight.
- The inverter can be operated in an ambient temperature range of -10 to 50 (carrier frequency and output current must be reduced between 40 to 50).

Notes on Use: Main Power Supply

Installation of an AC reactor on the input side	<p>In the cases below involving a general-purpose inverter, a large peak current flows on the main power supply side, and is able to destroy the converter module. Where such situations are foreseen or the connected equipment must be highly reliable, install an AC reactor between the power supply and the inverter. Also, where influence of an indirect lightning strike is possible, install a lightning conductor.</p> <p>(a) The unbalance factor of the power supply is 3% or higher(Note). (b) The power supply capacity is at least 10 times greater than the inverter capacity (the power supply capacity is 500kVA or more). (c) Abrupt power supply changes are expected.</p> <p>examples: (1) Several inverters are interconnected with a short bus. (2) A thyristor converter and an inverter are interconnected with a short bus. (3) An installed phase advance capacitor opens and closes.</p> <p>In cases (a), (b) and (c), it is recommended to install an AC reactor on the main power supply side.</p>
Using a private power generator	<ul style="list-style-type: none"> • An inverter run by a private power generator may overheat the generator or suffer from a deformed output voltage waveform from the generator. • Generally, generator capacity should be at least five times that of the inverter (kVA) in a PWM control system, or six times greater in a PAM control system.

Notes on Peripheral Equipment Selection

Wiring connections	<p>(1) Be sure to connect main power cables to L1, L2 (input) terminals and motor to U, V, and W terminals (output). (Incorrect connection will cause a breakdown.) (2) Be sure to ground the inverter frame using the ground terminal.</p>	
Wiring between inverter and motor	Electromagnetic contactor	If an electromagnetic contactor is installed between the inverter and the motor, do not perform on-off switching during running operation.
	Thermal relay	<p>When used with standard applicable output motors (Hyundai standard three-phase squirrel-cage four-pole motors), the N50 Series do not need a thermal relay for motor protection due to the internal electronic protective circuit. A thermal relay, however, should be used:</p> <p>(a) during continuous running at a range beyond 30 to 60 Hz. (b) for motors exceeding the range of electronic thermal adjustment relay for each motor. (c) when several motors are driven by one inverter; a thermal relay should be installed for each motor.</p> <p>The RC value of the thermal relay should be more than 1.1 times the rated current of the motor. Where the wiring length is 10m or more, the thermal relay tends to turn off readily. In this case, provide an AC reactor on the output side or use a current sensor.</p>
Installing a circuit breaker	<ul style="list-style-type: none"> • Install a circuit breaker on the main power input side to protect inverter wiring and ensure personal safety. • Choose an inverter-compatible circuit breaker. 	
Wiring distance	<ul style="list-style-type: none"> • The wiring length between the inverter and the remote operator panel should be 20 meters or less. • When this length is exceeded, use CVD-E (current-voltage converter) or RCD-E (remote control device). • Shielded cable should be used for the wiring. Be careful about the cable length to avoid line-voltage drop (A large voltage drop causes a decrease in torque). 	
Earth leakage relay	If the earth leakage relay (or earth leakage breaker) is used, it should have a sensitivity level of 15 mA or more (per inverter).	
Phase advance capacitor	Do not use a capacitor for power factor improvement between the inverter and the motor because the high-frequency components of the inverter output may overheat or damage the capacitor.	

High-Frequency Noise and Leakage Current

- High-frequency components are included in the input/output of the inverter main circuit, and they may cause interference in a transmitter, radio, or sensor if used near the inverter. The interference can be minimized by adopting noise filters (option).
- The switching action of an inverter causes an increase in leakage current. Be sure to ground the inverter and the motor.

Lifetime of Primary Parts

- Because a smoothing capacitor deteriorates as it undergoes internal chemical reaction, it should normally be replaced every five years. Be aware, however, that its life expectancy becomes considerably shorter when the inverter is subjected to such adverse factors such as high temperature, or heavy load exceeding the rated current of the inverter.
- Also, consumable parts such as cooling fans should be replaced according to the inverter periodic inspection of the maintenance guide (maintenance inspection and parts replacement must be performed by only specified trained personnel).

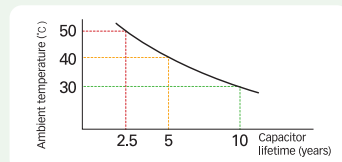

www.hyundai-elec.com



Head Office	1 Jeonha-dong, Dong-gu, Ulsan, Korea Tel. 82-52-230-8101~8 Fax. 82-52-230-8100
Seoul (Sales & Marketing)	140-2, Gye-dong, Jongno-gu, Seoul, Korea Tel. 82-2-746-7596, 7519 Fax. 82-2-746-7648
Orlando	3452 Lake Lynda Drive, Suite 170, Orlando, Florida 32817, U.S.A. Tel. 1-407-249-7350 Fax. 1-407-275-4940
London	2nd Floor, The Triangle, 5-17 Hammersmith Grove London, W6 0LG, UK Tel. 44-20-8741-0501 Fax. 44-20-8741-5620
Tokyo	8th Fl., Yurakucho Denki Bldg. 1-7-1, Yuraku-cho, Chiyoda-gu, Tokyo 100-0006, Japan Tel. 81-3-3212-2076, 3215-7159 Fax. 81-3-3211-2093
Cairo	Apartment No. 503, 5th Fl., Bldg. No. 7 Block 2, 9th Division, El-nasr Road, New Maadi, Cairo, Egypt Tel. 20-2-520-0148~9 Fax. 20-2-754-7528
Sofia	1271, Sofia 41, Rojen Blvd. Bulgaria Tel. 359-2-938-1068, 936-0300 Fax. 359-2-936-0742
Yangzhong	Lianzhong Avenue, Xinba Scientific and Technologic Zone, Yangzhong City, Jiangsu 212212, China Tel. 86-511-842-0666, 0500 Fax. 86-511-842-0668, 0231